

ENGINEERING
ADMISSIONS ASSESSMENT

D564/11

November 2021

60 minutes

SECTION 1

INSTRUCTIONS TO CANDIDATES

Please read these instructions carefully, but do not open this question paper until you are told that you may do so. This paper is Section 1 of 2.

A separate answer sheet is provided for this paper. Please check you have one. You also require a soft pencil and an eraser.

Please complete the answer sheet with your candidate number, centre number, date of birth, and name.

At the end of 60 minutes, your supervisor will collect this question paper and answer sheet before giving out Section 2.

This paper contains **two** parts, **A** and **B**, and you should attempt **both** parts.

Part A Mathematics and Physics (20 questions)

Part B Advanced Mathematics and Advanced Physics (20 questions)

You are **strongly** advised to divide your time equally between the two parts: 30 minutes on **Part A** and 30 minutes on **Part B**. The scores for Part A and Part B are reported separately.

This paper contains 40 multiple-choice questions. There are no penalties for incorrect responses, only marks for correct answers, so you should attempt **all** 40 questions. Each question is worth one mark.

For each question, choose the **one** option you consider correct and record your choice on the separate answer sheet. If you make a mistake, erase thoroughly and try again.

You **must** complete the answer sheet within the time limit.

You can use the question paper for rough working, but **no extra paper** is allowed. Only your responses on the answer sheet will be marked.

Dictionaries and calculators are NOT permitted.

Please wait to be told you may begin before turning this page.

This question paper consists of 35 printed pages and 5 blank pages.



BLANK PAGE

PART A Mathematics and Physics

1 Simplify fully

$$5xy^2 \times (5x^2y)^{-3} \times 5x^2y$$

where x and y are positive.

A $\frac{1}{125x^7y^2}$

B $\frac{1}{125x^6y^2}$

C $\frac{1}{25x^6y}$

D $\frac{1}{25x^4y}$

E $\frac{1}{5x^3}$

F $\frac{1}{5x^2}$

G $\frac{y}{x^2}$

H $5xy^2$

- 2 Air is trapped in a cylinder by a piston. The density of the air in the cylinder is ρ .

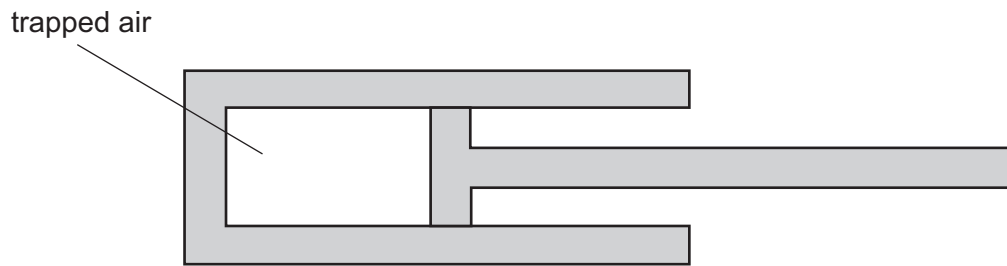

The piston is moved so that the pressure of the trapped air increases by 20%. The temperature of the trapped air does not change.

What is the new density of the trapped air?

(Assume that air is an ideal gas.)

- A 0.69ρ
- B 0.80ρ
- C 0.83ρ
- D 1.00ρ
- E 1.20ρ
- F 1.44ρ

3 Which of the following is a rearrangement of

$$\frac{p}{2} + \frac{3}{q} = \frac{4}{r}$$

so that q is the subject?

A $q = \frac{2r}{24 - 3pr}$

B $q = \frac{3r}{2r - p}$

C $q = \frac{6r}{4 - p}$

D $q = \frac{6r}{8 - pr}$

E $q = \frac{r - 2}{12p}$

F $q = \frac{3r - 6}{4p}$

G $q = \frac{pr - 8}{12p}$

H $q = \frac{3pr - 24}{4p}$

- 4 A **non-ideal** transformer has 100 turns on the primary coil and 25 turns on the secondary coil. It is provided with 3.0 kW of electrical power at a current of 12.5 A. The voltage output is the same as for an ideal transformer, but the current in the output coil is 40 A.

What is the efficiency of the transformer?

- A 20%
- B 25%
- C 31%
- D 69%
- E 75%
- F 80%
- G 91%
- H 100%

- 5 Two solid cylinders, P and Q, are shown, where $x > y$.

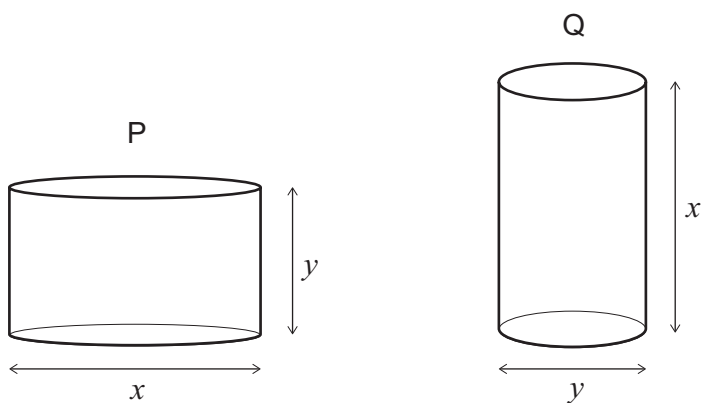

Cylinder P has diameter x and height y .

Cylinder Q has diameter y and height x .

What is the positive difference between the total surface areas of P and Q?

- A 0
- B $\frac{\pi}{4}(x^2 - y^2)$
- C $\frac{\pi}{2}(x^2 - y^2)$
- D $\pi(x^2 - y^2)$
- E $2\pi(x^2 - y^2)$
- F $\frac{\pi}{4}xy(x - y)$
- G $\pi xy(x - y)$

- 6 A light spring has an uncompressed length of 0.10 m. When an object of mass 0.5 kg rests in equilibrium on top of the spring, the length of the spring reduces to 0.08 m as shown.



What is the energy stored in the spring due to the compression?

(gravitational field strength = 10 N kg^{-1} ; the spring obeys Hooke's law)

- A 0.005 J
 B 0.02 J
 C 0.05 J
 D 0.1 J
 E 0.2 J
 F 0.4 J
- 7 The price of item P is reduced by 10%. The next day, the new price is increased by 10%.
 The price of item Q is increased by 10%. The next day, the new price is reduced by 10%.
 How does the final price of each item compare to the original price of that item?

	<i>item P final price</i>	<i>item Q final price</i>
A	lower than original	lower than original
B	lower than original	higher than original
C	higher than original	lower than original
D	higher than original	higher than original
E	the same as original	the same as original

- 8 A set of decorative lights consists of 20 lamps connected in series to a dc supply of constant voltage.

The total power transferred by all the lamps is P .

The set is designed so that if one of the lamps fails, that lamp becomes short-circuited and it then has zero resistance. The remaining lamps are still lit.

If this happens, with the set connected to the same supply, what is the new total power transferred by the remaining 19 lamps?

(Assume that the resistance of each functioning lamp remains constant.)

A $\left(\frac{19}{20}\right)^2 P$

B $\left(\frac{19}{20}\right) P$

C P

D $\left(\frac{20}{19}\right) P$

E $\left(\frac{20}{19}\right)^2 P$

9

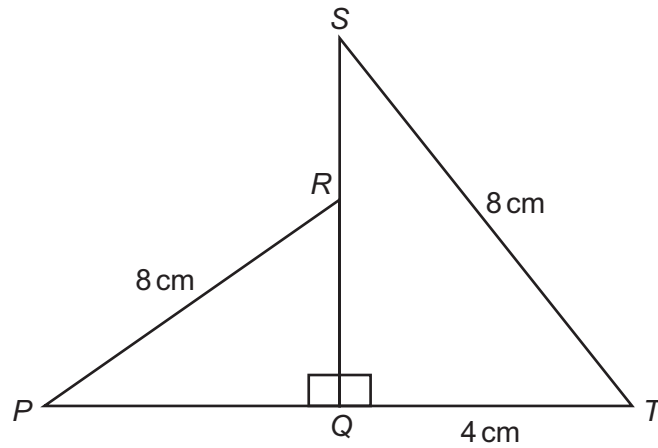

[diagram not to scale]

SQT is a right-angled triangle with the right angle at Q .

The point R is on SQ such that $SR:RQ = 1:3$

QRP is a right-angled triangle with the right angle at Q .

$PR = ST = 8$ cm

$QT = 4$ cm

What is the length of PQ , in cm?

- A $2\sqrt{3}$
- B $4\sqrt{3}$
- C $\sqrt{19}$
- D $\sqrt{37}$
- E $\sqrt{55}$
- F $\sqrt{61}$

10 A train accelerates from rest along a straight, horizontal section of track.

The force exerted on the train due to its motors is constant and there is a constant friction force of $1.8 \times 10^7 \text{ N}$.

The graph shows how the momentum of the train changes with time.

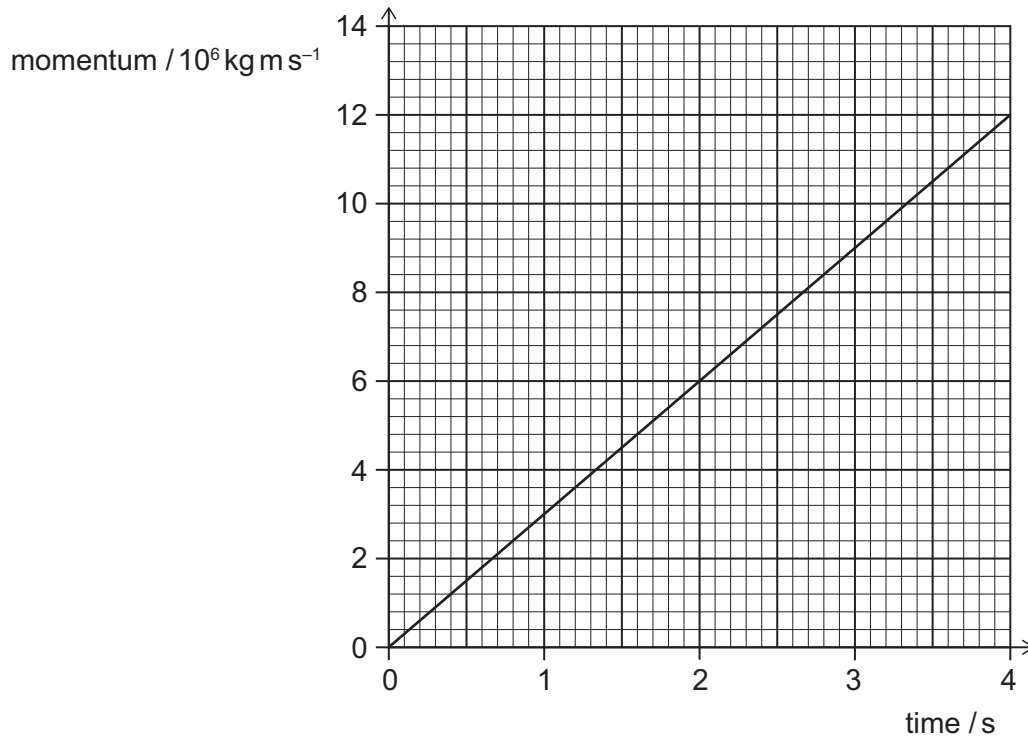

What is the force exerted on the train due to its motors?

- A $3.0 \times 10^6 \text{ N}$
- B $6.0 \times 10^6 \text{ N}$
- C $1.2 \times 10^7 \text{ N}$
- D $1.5 \times 10^7 \text{ N}$
- E $2.1 \times 10^7 \text{ N}$
- F $2.4 \times 10^7 \text{ N}$
- G $3.0 \times 10^7 \text{ N}$
- H $4.2 \times 10^7 \text{ N}$

- 11 The curve with equation $y = x^2 - 4x + 5$ meets the straight line with equation $y = 2x + c$ at two points, which have x -coordinates p and q , where $q > p$.

Given that $q - p = 8$, what is the value of the constant c ?

- A -43
- B -12
- C -2
- D 0
- E 2
- F 12
- G 43

- 12 A ship travels into a wave that is travelling in the opposite direction to the ship.

The ship has a horizontal speed of 8.0 m s^{-1} . The speed of the wave is 3.0 m s^{-1} .

The front of the ship rises and falls with a time period of 8.0 s .

What is the wavelength of the wave?

- A $\frac{3}{8} \text{ m}$
- B $\frac{5}{8} \text{ m}$
- C 1.0 m
- D $\frac{11}{8} \text{ m}$
- E 24 m
- F 40 m
- G 64 m
- H 88 m

13 Given that

$$y = \frac{\sin 60^\circ - 1}{\cos 60^\circ}$$

what is the value of y^3 ?

- A $-\frac{\sqrt{3}}{9}$
- B $-5\sqrt{2} + 10$
- C $3\sqrt{3} - 8$
- D $6\sqrt{3} - 10$
- E $14\sqrt{2} - 20$
- F $15\sqrt{3} - 26$
- G $21\sqrt{3} - 38$

- 14 A 6.0V battery is connected to an 8.0Ω resistor and a filament lamp as shown in the circuit diagram.

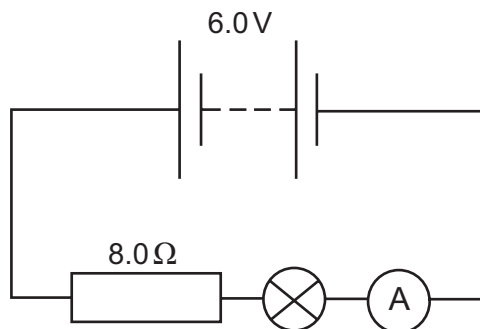

The reading on the ammeter is 0.25A.

Which graph is a possible $V-I$ graph for the filament lamp?

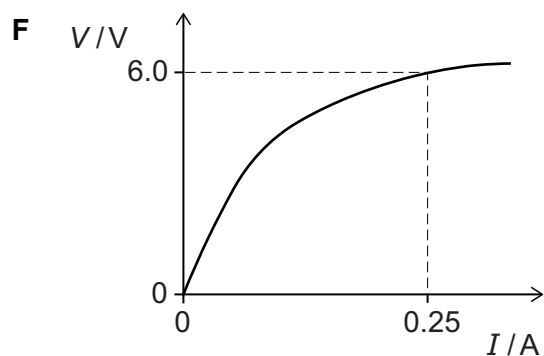
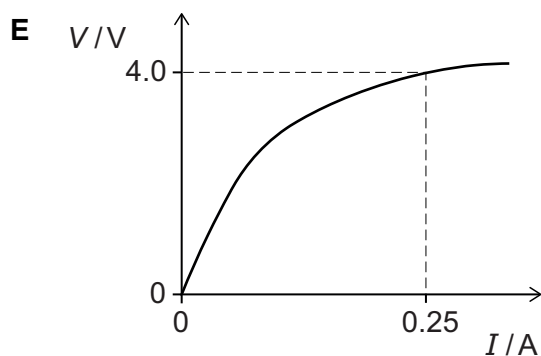
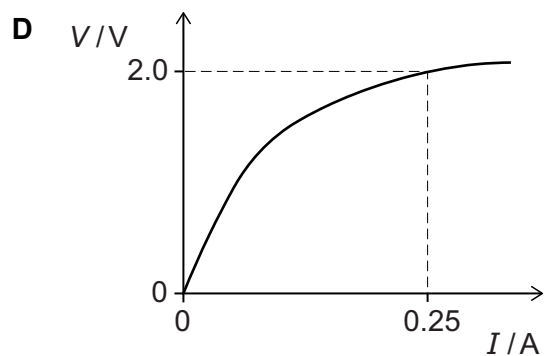
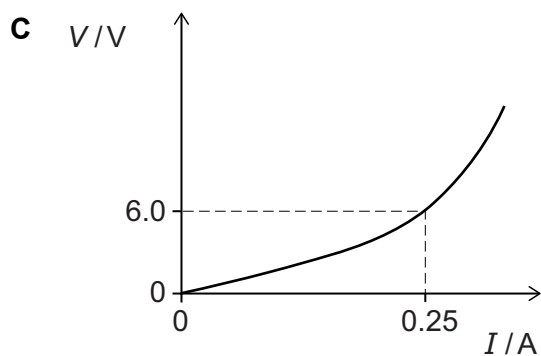
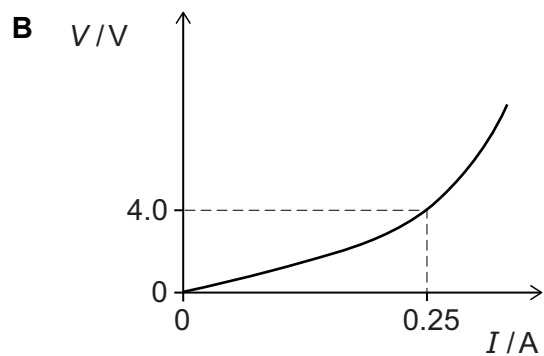
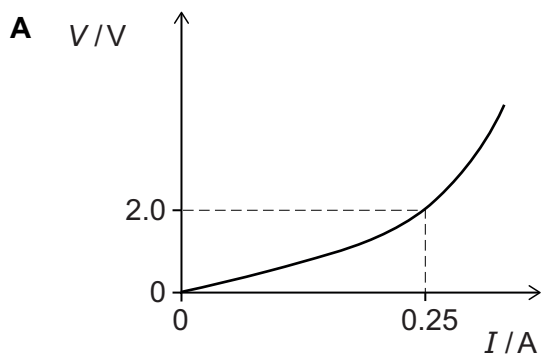

- 15** Charlie has a bowl containing red sweets and green sweets only. The sweets are identical in all respects except colour.

There are nine sweets in total in the bowl.

Charlie eats two sweets from the bowl at random.

The probability of Charlie not eating any green sweets is $\frac{5}{12}$

What is the probability that Charlie eats two green sweets?

A $\frac{2}{27}$

B $\frac{1}{12}$

C $\frac{1}{9}$

D $\frac{4}{27}$

E $\frac{1}{6}$

F $\frac{1}{4}$

G $\frac{7}{12}$

16 A radioactive nuclide X decays in a single stage to a stable nuclide R.

A radioactive nuclide Y decays in a single stage to a stable nuclide S.

When a rock formed it contained equal numbers of atoms of all four nuclides X, Y, R and S.

The half-life of X is T years and the half-life of Y is $2T$ years.

What is the value of $\frac{\text{number of atoms of R}}{\text{number of atoms of S}}$ at a time $4T$ years after the rock has formed?

(Assume that no other processes add or remove X, Y, R or S from the rock during this time.)

A $\frac{1}{4}$

B $\frac{17}{20}$

C $\frac{31}{28}$

D $\frac{6}{5}$

E $\frac{5}{4}$

F 2

- 17 The greatest diagonal distance between the two vertices of a cuboid, as shown in the diagram, is $\sqrt{77}$ cm.

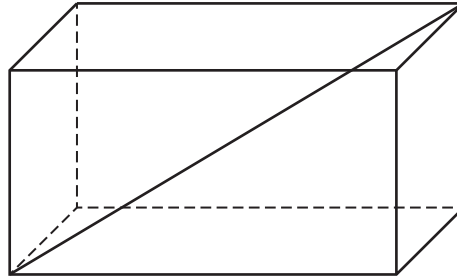

A similar cuboid has all its lengths exactly half the lengths of the original cuboid.

The sides of this smaller cuboid are 2 cm, 3 cm and x cm.

What is the value of x , in cm?

- A $\frac{5}{2}$
- B 5
- C $\frac{5\sqrt{2}}{2}$
- D $5\sqrt{2}$
- E $\frac{\sqrt{102}}{2}$
- F $\sqrt{102}$

18 A beaker containing 180 g of water at 25 °C has a 20 g ice cube at 0 °C added to it.

No heat is transferred between the water and the surroundings (including the beaker).

What is the final temperature of all the water in the beaker after all the ice has melted?

(Take the specific heat capacity of water to be $4 \text{ J g}^{-1} \text{ °C}^{-1}$ and the specific latent heat of fusion of water to be 300 J g^{-1} .)

A 2.5 °C

B 8.3 °C

C 10.0 °C

D 15.0 °C

E 16.7 °C

F 22.5 °C

19 A car journey is m miles long.

One kilometre is equivalent to x miles.

The car uses one litre of fuel to travel a distance of f kilometres.

Fuel for the car costs p pence per litre.

Which of the following expressions gives the cost of fuel for this journey, in pounds?

(There are 100 pence in one pound.)

A $100fmpx$

B $\frac{100fmp}{x}$

C $\frac{100mpx}{f}$

D $\frac{100mp}{fx}$

E $\frac{fmpx}{100}$

F $\frac{fmp}{100x}$

G $\frac{mpx}{100f}$

H $\frac{mp}{100fx}$

- 20 A pulse of ultrasound travels from one end of a solid uniform rod of length L , starting at time $t = 0$.

The pulse is partially reflected by a crack in the rod and partially by the far end of the rod.

These two reflected pulses travel back along the rod, arriving at the end from which they started at times t_1 and t_2 , where $t_2 > t_1$.

What is the distance between the crack and the **far end** of the rod?

- A $\frac{t_1}{t_2} L$
- B $\frac{t_2}{t_1} L$
- C $\frac{t_1}{2t_2} L$
- D $\frac{t_2}{2t_1} L$
- E $\frac{(t_2 - t_1)}{t_2} L$
- F $\frac{(t_2 - t_1)}{2t_2} L$

BLANK PAGE

PART B Advanced Mathematics and Advanced Physics

21 Given that

$$y = \left(2\sqrt{x} - \frac{1}{2\sqrt{x}} \right)^2$$

find the value of $\frac{dy}{dx}$ when $x = \frac{1}{2}$

- A -12
- B $-\frac{1}{4}$
- C 3
- D $\frac{63}{16}$
- E 5

22 Object P of mass 2.4 kg is on a smooth plane inclined at an angle of 60° to the horizontal. A constant force of magnitude $2F$ parallel to the plane is applied to P. As a result P moves directly up the plane with constant velocity.

Object Q of mass 0.75 kg is on a smooth, horizontal plane. A constant force of magnitude F parallel to the plane is applied to Q. As a result Q moves along the plane with constant acceleration.

What is the acceleration of Q?

(gravitational field strength = 10 N kg^{-1})

- A 4.5 ms^{-2}
- B 6.0 ms^{-2}
- C 8.0 ms^{-2}
- D 16 ms^{-2}
- E $4.5\sqrt{3} \text{ ms}^{-2}$
- F $6.0\sqrt{3} \text{ ms}^{-2}$
- G $8.0\sqrt{3} \text{ ms}^{-2}$
- H $16\sqrt{3} \text{ ms}^{-2}$

23 A particular arithmetic series has first term a and common difference d .

The sum of the first k terms of this series is denoted by S_k

Which of the following is a simplification of $S_{n+1} - S_{n-1}$?

A d

B $2d$

C $2a + d$

D $2a + 2d$

E $2a + nd$

F $2a + 2nd$

G $2a + (2n - 1)d$

H $2a + (4n - 2)d$

- 24 A sound wave is travelling from left to right in air. The diagram represents the wave at a particular instant, and a distance of 33 cm is labelled.

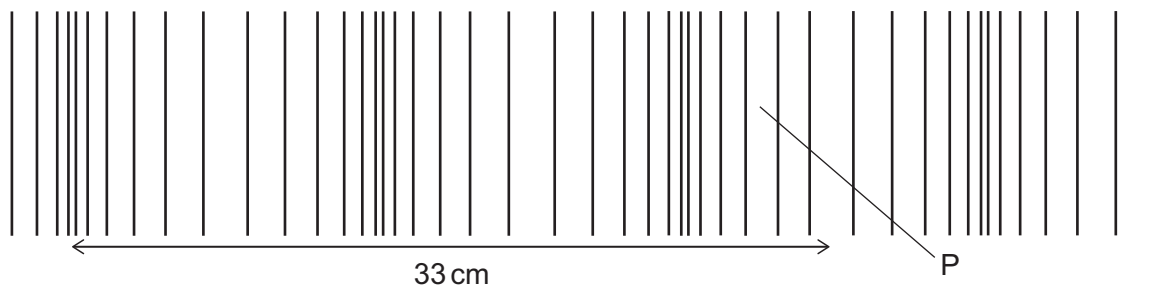

The speed of sound in air is 330 m s^{-1} .

What is the frequency of the sound and in which direction has the air at P been displaced from its mean position?

	<i>frequency of sound / Hz</i>	<i>displacement of air at P</i>
A	1000	to the left
B	2500	to the left
C	5000	to the left
D	1000	to the right
E	2500	to the right
F	5000	to the right

- 25 Find how many distinct real solutions there are to the equation

$$(x^2 + 4x + 3)^2 = 1$$

- A** 0
- B** 1
- C** 2
- D** 3
- E** 4

26 A resistor R is connected between terminals X and Y in the circuit shown.

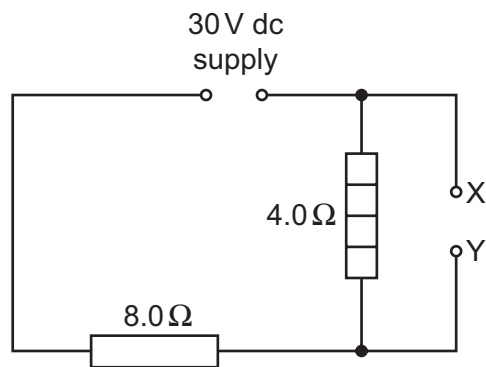

The power transferred in the 4.0Ω heater is 9.0 W .

What is the resistance of R?

- A 1.6Ω
- B 2.0Ω
- C 2.67Ω
- D 4.0Ω
- E 8.0Ω

27 The line $x = 1$ divides the circle $x^2 + y^2 = 4$ into two segments.

What is the area of the smaller segment?

A $\frac{2\pi}{3} - \frac{\sqrt{3}}{2}$

B $\frac{2\pi}{3} - \sqrt{3}$

C $\frac{\pi}{2} - \frac{1}{2}$

D $\frac{\pi}{2} - 1$

E $\pi - \frac{1}{2}$

F $\pi - 1$

G $\frac{4\pi}{3} - \frac{\sqrt{3}}{2}$

H $\frac{4\pi}{3} - \sqrt{3}$

28 A uniform plank of length 5.0 m rests horizontally as shown.

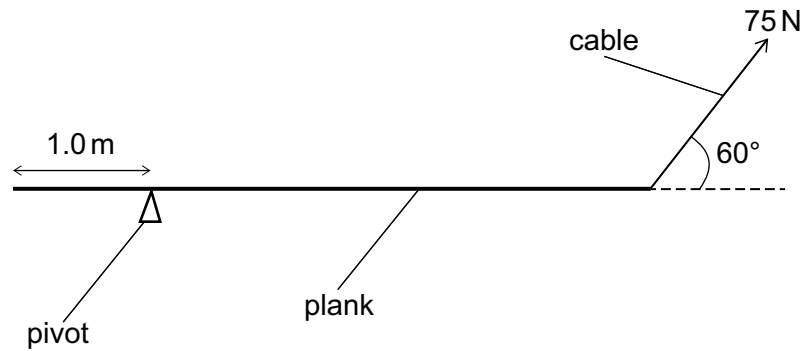

[diagram not to scale]

There is a pivot 1.0 m from one end of the plank.

A cable at an angle of 60° to the horizontal supports the plank at the other end so that it is in equilibrium.

The tension in the cable is 75 N.

What is the weight of the plank?

- A 60 N
- B $60\sqrt{3}$ N
- C 100 N
- D $100\sqrt{3}$ N
- E 125 N
- F $125\sqrt{3}$ N

29 What is the mean of $\log_{10} 27$, $\log_{10} 64$, and $\log_{10} 216$?

A $\frac{\log_{10} 307}{3}$

B $\frac{\log_{10} 81}{3}$

C $\frac{\log_{10} 6^{12}}{3}$

D $\log_{10} 64$

E $\log_{10} 72$

F $\log_{10} 108$

30 A lorry accelerates along a straight, horizontal road with uniform acceleration.

Oil droplets from the lorry fall a small distance onto the road at a constant rate. The time interval between successive drips is t .

The diagram shows four successive oil droplets on the road after the lorry has passed.



The distance between the first two of these droplets is x and the distance between the final two is y .

Which expression gives the acceleration of the lorry?

A $\frac{y-x}{3t^2}$

B $\frac{y-x}{2t^2}$

C $\frac{y-x}{t^2}$

D $\frac{2(y-x)}{t^2}$

E $\frac{y+x}{t^2}$

F $\frac{y+x}{3t^2}$

31 Which of the following is the largest in value?

(All angles are in radians.)

A $\cos 0.5$

B $\cos 0.75$

C $\cos 1$

D $\sin 0.5$

E $\sin 0.75$

F $\sin 1$

32 A light, metal wire of length 2.5 m and cross-sectional area $1.8 \times 10^{-6} \text{ m}^2$ is suspended vertically. A mass of 7.2 kg is attached to the lower end of the wire. The wire extends by 0.50 mm.

What is the Young modulus of the metal and how much energy is stored in the extended wire?

(gravitational field strength = 10 N kg^{-1} ; assume that the wire obeys Hooke's law and that changes in the cross-sectional area are negligible)

	<i>Young modulus / Pa</i>	<i>energy stored / J</i>
A	5.0×10^{-12}	0.018
B	5.0×10^{-12}	0.036
C	2.0×10^{11}	0.018
D	2.0×10^{11}	0.036
E	2.0×10^{14}	18
F	2.0×10^{14}	36

- 33** A geometric progression has first term $u_1 = a$ and common ratio r .

The sum to infinity of the geometric progression is $\frac{8}{5}$

The sum to infinity of the even-numbered terms ($u_2 + u_4 + u_6 + \dots$) is $\frac{3}{5}$

What is the value of $a + r$?

A $\frac{3}{5}$

B $\frac{31}{25}$

C $\frac{23}{5}$

D $\frac{28}{5}$

E $\frac{67}{8}$

- 34** A child of mass 30 kg is on a sledge of mass 10 kg which is moving down a smooth slope at an instantaneous speed of 4.0 m s^{-1} .

At this instant, the child jumps backwards off the sledge and lands stationary on the slope.

What is the speed of the sledge immediately after the child jumps off?

A 4.0 m s^{-1}

B 8.0 m s^{-1}

C 12 m s^{-1}

D 16 m s^{-1}

E 20 m s^{-1}

- 35 At how many distinct points do the following two curves meet?

$$y = (x - 4)(x^2 - 2x - 8)$$

$$y = -x^2 + 8x - 16$$

- A 0
B 1
C 2
D 3
E 4
F 5
- 36 A piece of electrically conducting putty is formed into the shape of a uniform cylinder. The resistance between the ends of the cylinder is R .
- The same piece of putty is now formed into a new uniform cylinder with half the diameter of the first cylinder.
- What is the resistance between the ends of the new cylinder?
- A $\sqrt{2}R$
B $2\sqrt{2}R$
C $4\sqrt{2}R$
D $2R$
E $4R$
F $8R$
G $16R$

37 Evaluate

$$\frac{3}{\sqrt{27} + \sqrt{21}} + \frac{3}{\sqrt{24} + \sqrt{18}} + \frac{3}{\sqrt{21} + \sqrt{15}} + \dots + \frac{3}{\sqrt{9} + \sqrt{3}}$$

A $\frac{3\sqrt{2}}{2}$

B $3\sqrt{2}$

C $\frac{3\sqrt{3}}{2}$

D $\sqrt{3}$

E $1 + \sqrt{2}$

F $3(1 + \sqrt{2})$

G $\frac{\sqrt{3}}{3} \left(1 + \frac{\sqrt{2}}{2} \right)$

H $\sqrt{3} \left(1 + \frac{\sqrt{2}}{2} \right)$

38 A car accelerates from rest in a straight line. During the first 10 s, its acceleration, a , in ms^{-2} is given by the equation

$$a = 4.0 - 0.36t$$

where t is the time in seconds.

What is its displacement from its original position after 10 s?

A 22 m

B 110 m

C 136 m

D 140 m

E 220 m

F 1100 m

G 1360 m

H 1400 m

39

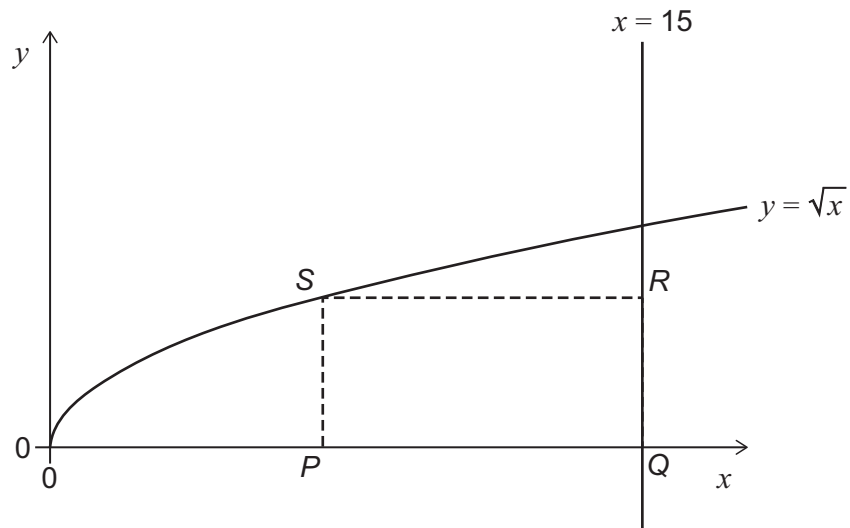

$PQRS$ is a rectangle.

P and Q lie on the x -axis.

Q and R lie on the line $x = 15$

S lies on the curve $y = \sqrt{x}$

What is the maximum possible area of the rectangle?

- A $5\sqrt{5}$
- B $10\sqrt{5}$
- C 50
- D $25\sqrt{5}$
- E 100
- F 125

- 40** Two trolleys are free to move on a smooth one-dimensional track. A light spring is compressed between the two stationary trolleys, the trolleys are released and then separate.

The trolleys have masses m and $4m$ and the work done by the spring as it expands is W . Assume that no work is done against frictional forces.

What is the difference in kinetic energy between the two trolleys when the spring has expanded?

- A** 0
- B** $\frac{W}{5}$
- C** $\frac{W}{4}$
- D** $\frac{W}{2}$
- E** $\frac{3W}{5}$
- F** $\frac{3W}{4}$
- G** $\frac{4W}{5}$
- H** W

END OF TEST

BLANK PAGE

BLANK PAGE

BLANK PAGE

